

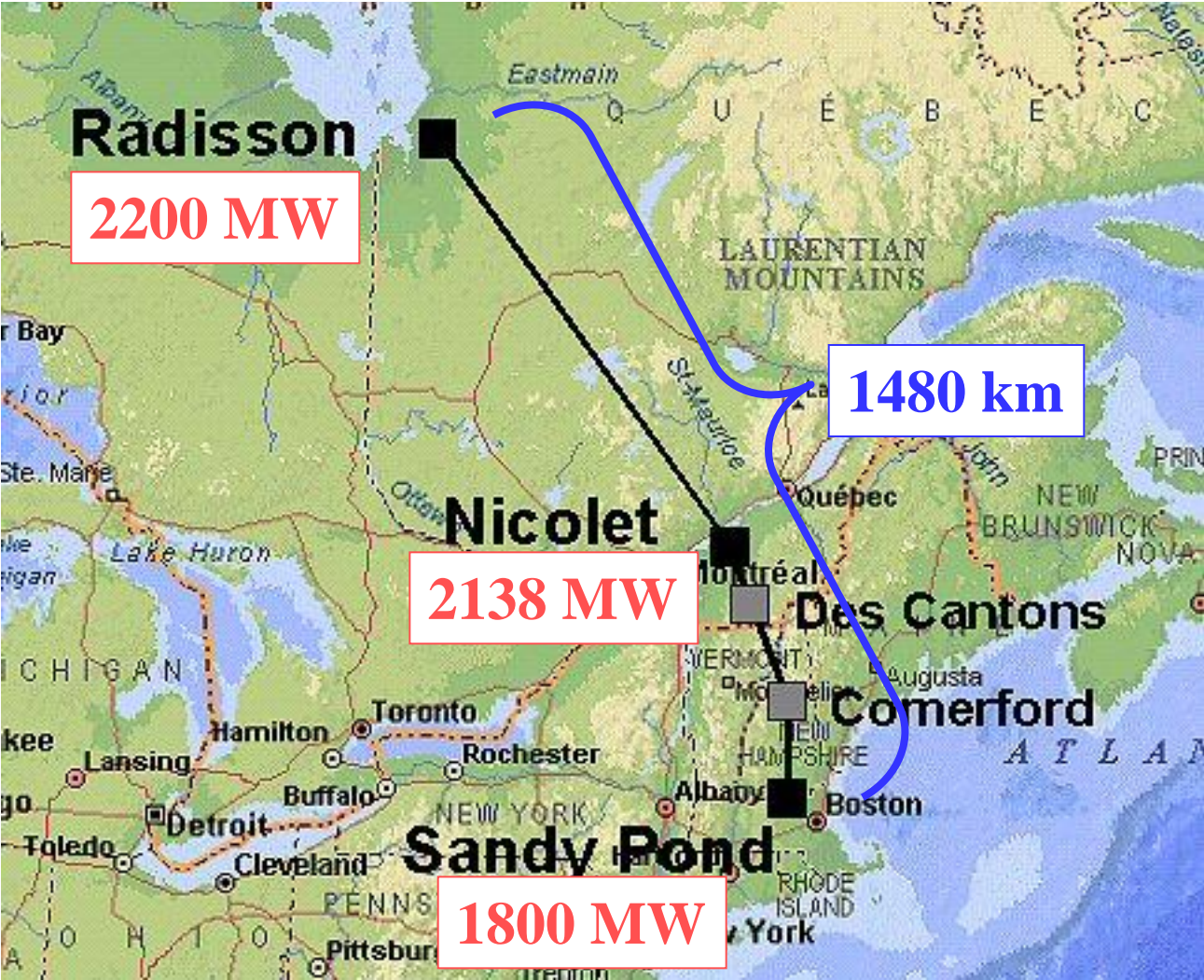

Gunnar Asplund, Power Systems – HVDC, ABB, B4 Colloquium, Bergen, June 12 2009

HVDC net - possibilities and challenges

Existing multi terminal scheme



HVDC technology for HVDC net

	LCC	VSC
Power reversal	Mechanical switches for voltage reversal as current cannot change sign	Change of current in the converter. No need for mechanical switches
AC disturbances	Commutation failure- short circuit of the dc grid for some time	No more influence than some loss of active power
DC side short circuit	DC breaker needed in a bigger net	DC breaker needed also in small net

Conclusion: Use VSC technology for an HVDC net

Point to point transmissions

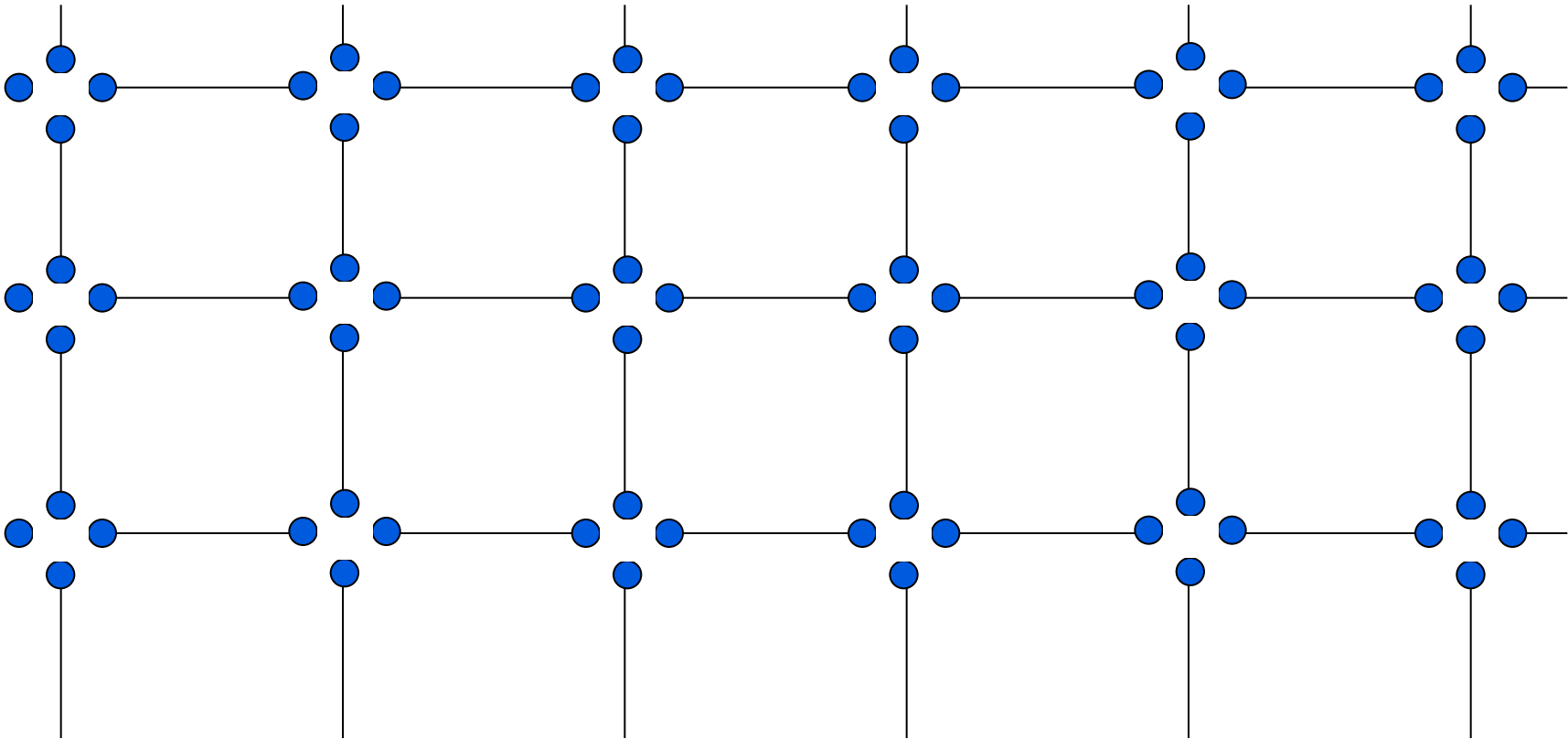

Grid: 1/4 of the stations needed

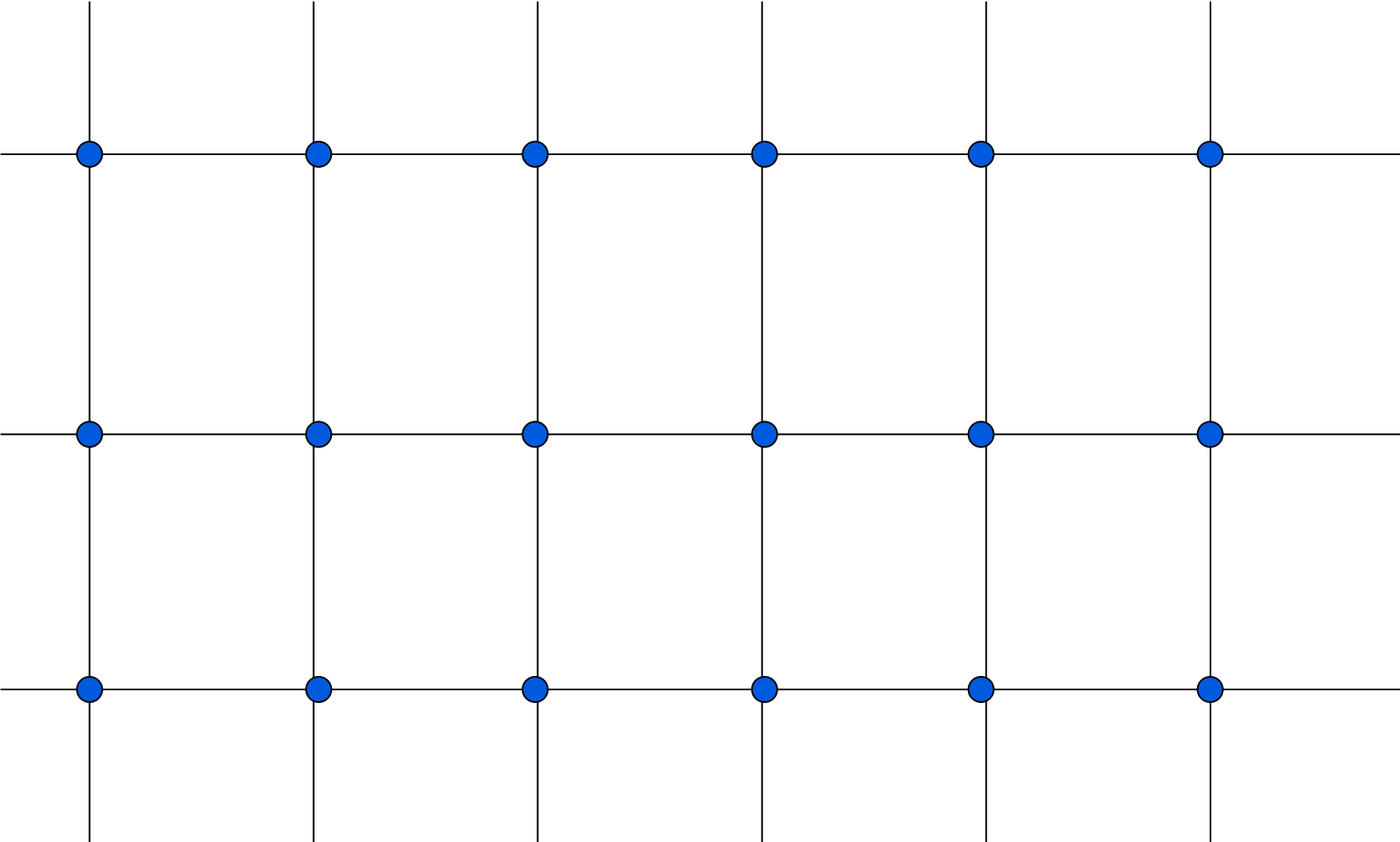

Load flow control

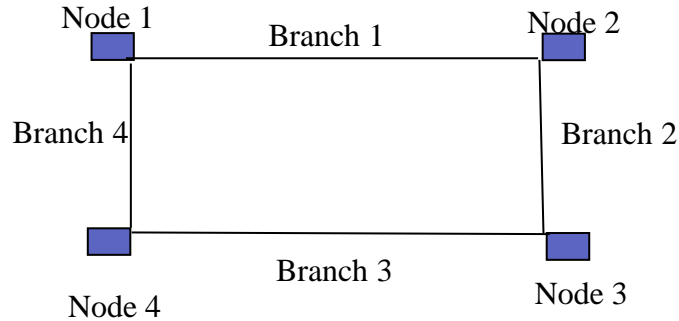

$$I_1 = \frac{U_2 - U_1}{R_{12}}$$

$$I_2 = \frac{U_3 - U_2}{R_{23}}$$

$$I_3 = \frac{U_4 - U_3}{R_{34}}$$

$$I_4 = \frac{U_1 - U_4}{R_{14}}$$

We have four equations and four unknown. All branch currents can be controlled by the node voltages.

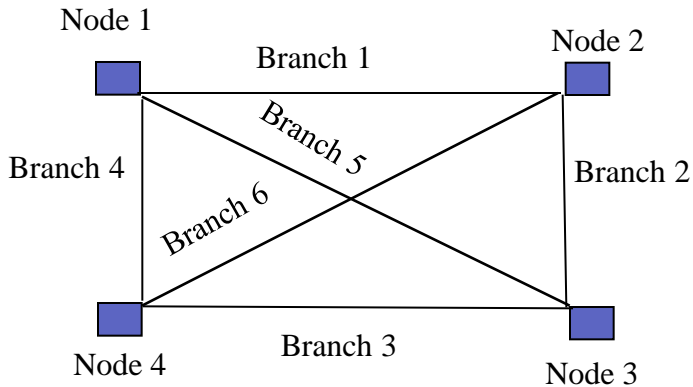

$$I_1 = \frac{U_2 - U_1}{R_{12}}$$

$$I_2 = \frac{U_3 - U_2}{R_{23}}$$

$$I_3 = \frac{U_4 - U_3}{R_{34}}$$

$$I_4 = \frac{U_1 - U_4}{R_{14}}$$

$$I_5 = \frac{U_3 - U_1}{R_{13}}$$

$$I_6 = \frac{U_4 - U_2}{R_{24}}$$

We have six currents and four voltages. It will only be possible to get exact control of four currents.

DC breakers

Mechanical
~60 ms, 5 kA presently

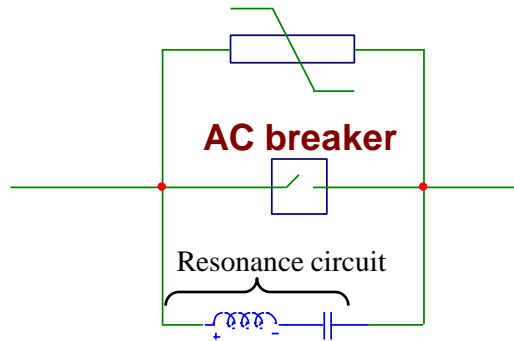

Electronic
~1 us, 5 kA presently

Single polarity

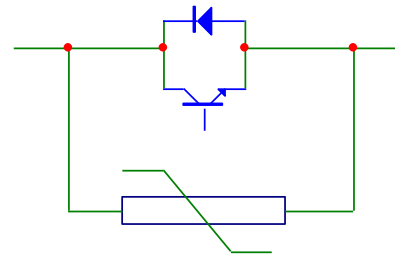

Double polarity

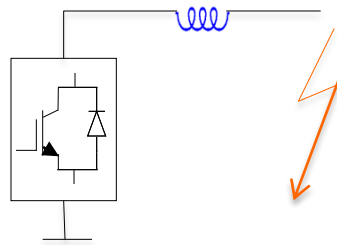
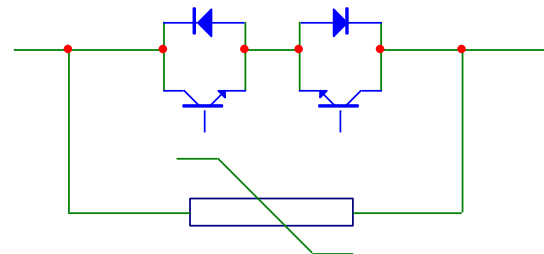

100 mH, 320 kV
gives 192 kA in 60 ms

HVDC switchyard

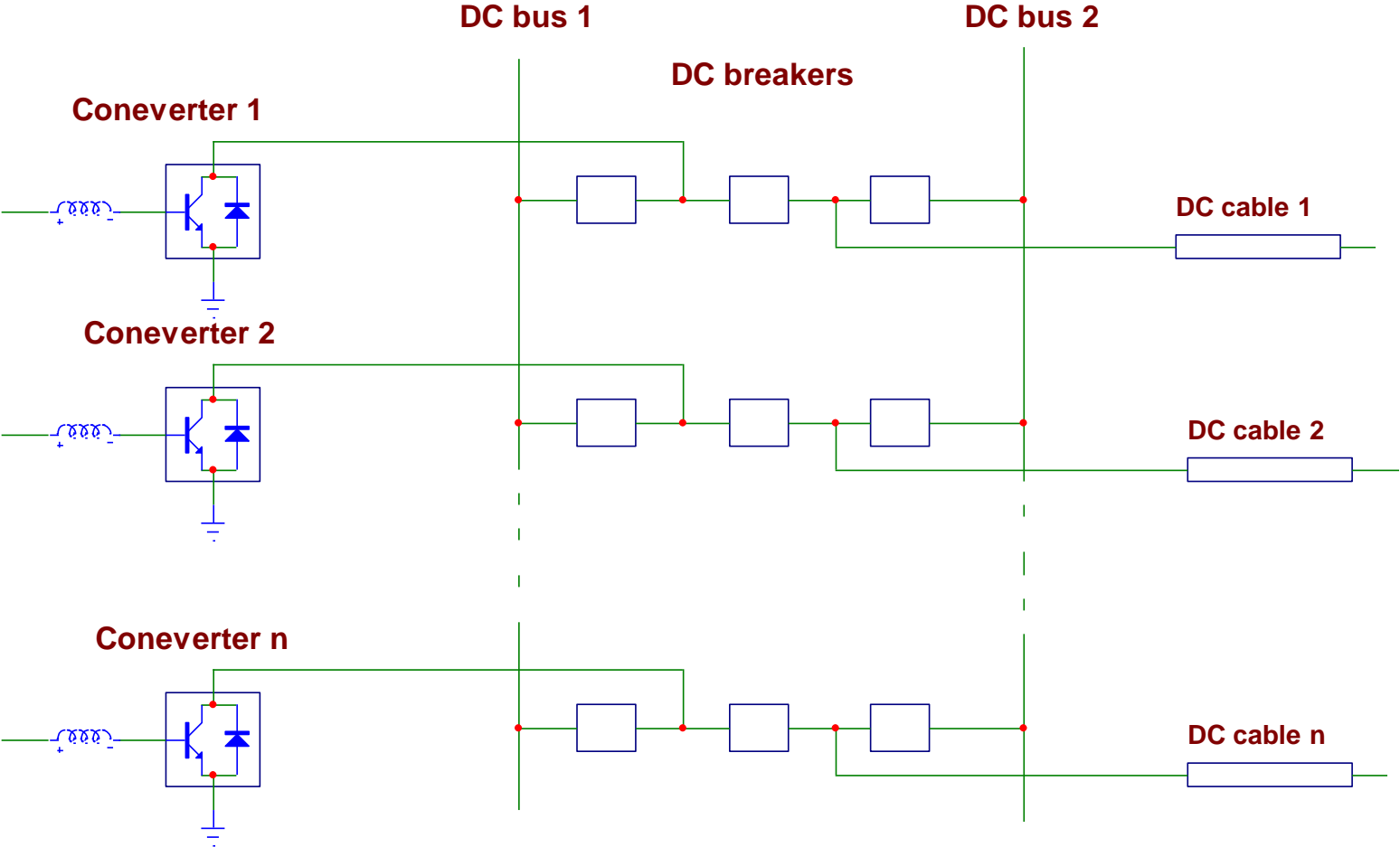

Grounding options

High impedance grounding

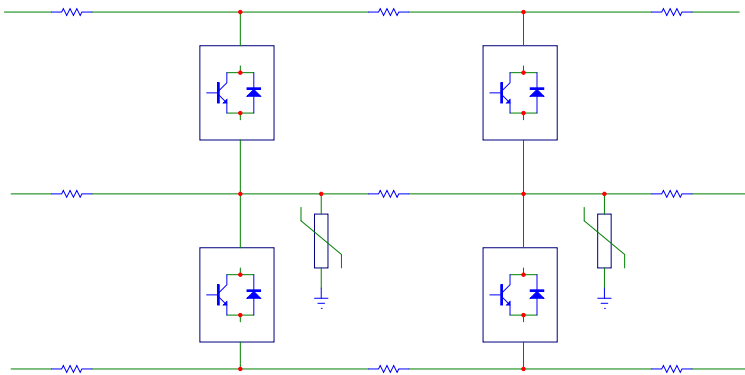

- **Monopolar operation through neutral cables is possible**
- **The whole net will have somewhat undefined voltage to ground**
- **DC faults will strongly influence the whole net**

Firm grounding

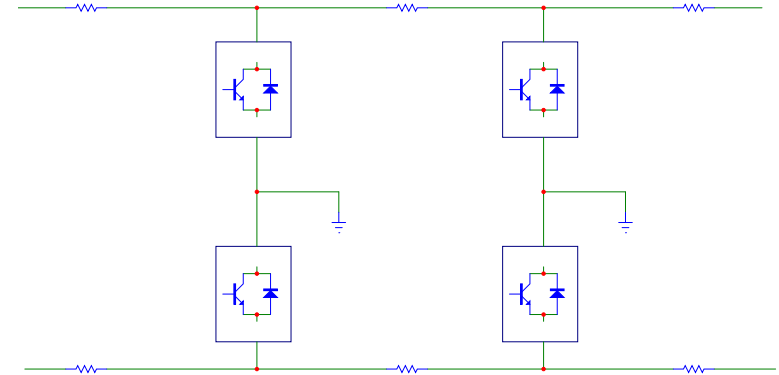

- **The net is firmly grounded and voltages are well defined to ground**
- **Not possible to operate monopolar unless ground current is allowed**

Protections

- Measure current and voltage
- Fast-100 mH and 320 kV gives current rise of 3200 A/ms
- Selective- take out only the faulty line

Voltage levels without transformer

Uac		Udc- one converter			Udc- two converters		
145	kV	+/-	110	kV	+/-	220	kV
245	kV	+/-	187	kV	+/-	374	kV
420	kV	+/-	320	kV	+/-	640	kV
525	kV	+/-	400	kV	+/-	800	kV

Possible future European- North African HVDC net

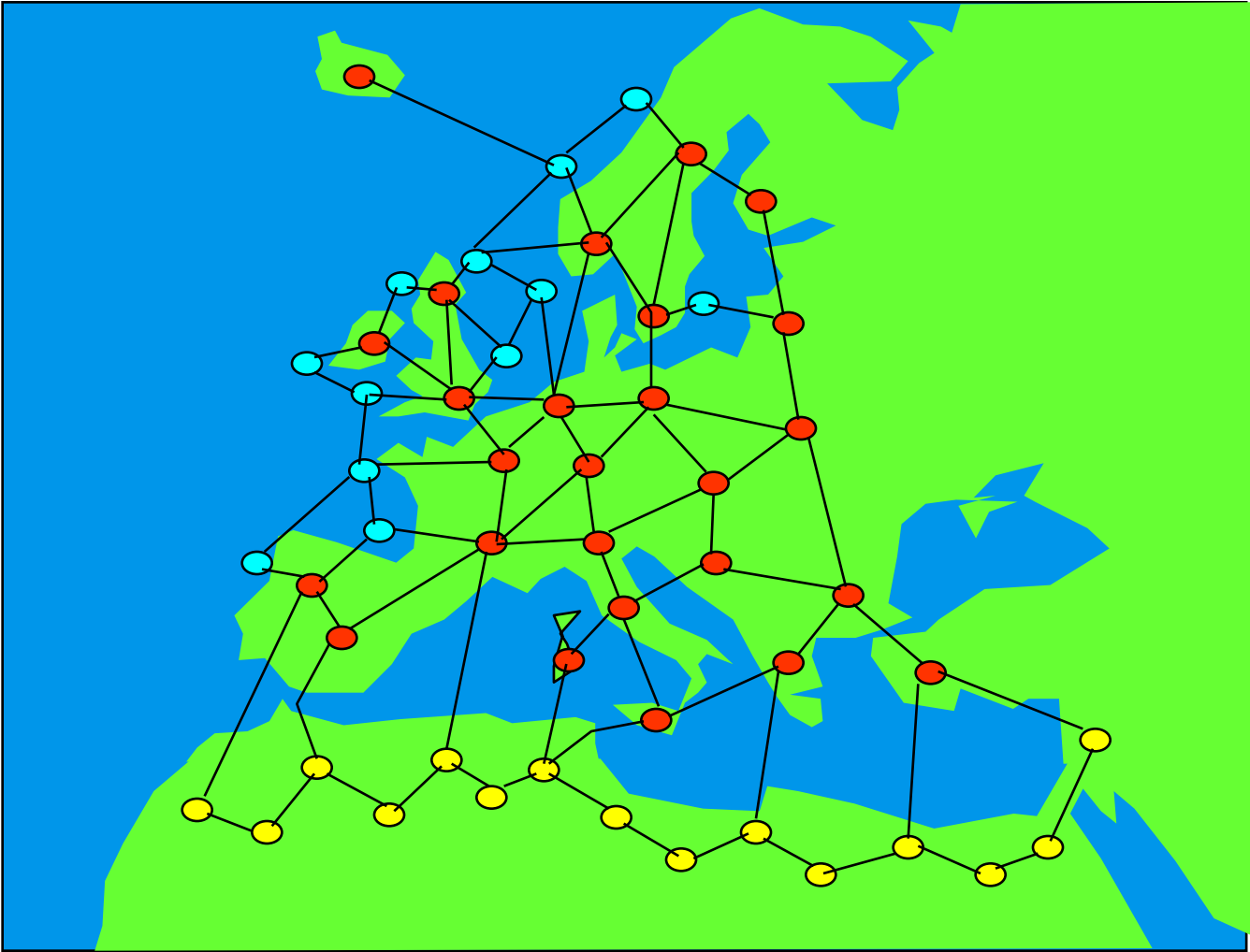

Europe 20XX Scenario

99LFC0825

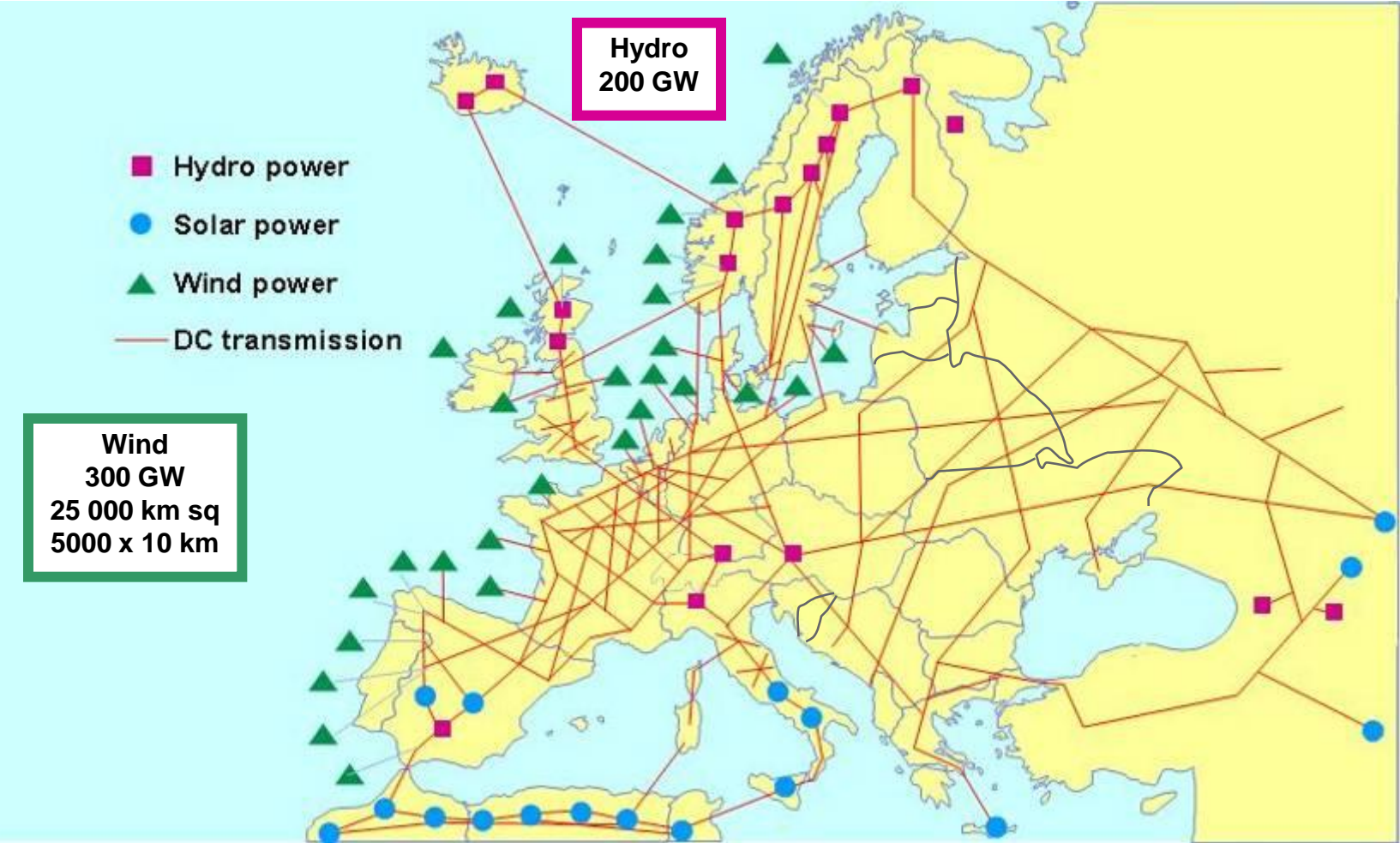

Hydro
200 GW

- Hydro power
- Solar power
- ▲ Wind power
- DC transmission

Wind
300 GW
25 000 km sq
5000 x 10 km

Solar
700 GW
8000 km sq
90 x 90 km

HVDC net- conclusions

- Wind, solar and trade increase the need of an overlay net in Europe and USA
- An UHVAC overlay net could solve the new challenges. The problem is acceptance of new lines and crossing of water where cables are needed
- New development makes HVDC net possible. Cables could be used where overhead lines are not accepted or where water should be crossed
- To build an HVDC grid requires standardization of voltages, control and protection

Power and productivity
for a better world™

