

## **HVDC grids - possibilities and challenges**

**Gunnar Asplund**

**ABB Power Systems**

**Sweden**

### **SUMMARY**

In many places there is a demand for new transmission capacity as new generation, much of it renewable, is added in places where the existing grid capacity is not sufficient. Building new HVAC overhead lines is often slow because of permissions. HVDC easily allows parts of the transmission to go underground or under water. An HVDC grid could from this point of view offer an interesting alternative to an ac overlay grid.

Up till now HVDC has been used for point to point transmission with two terminals and in a few cases three terminals. It has been considered very complicated to build a meshed HVDC network. HVDC using VSC (Voltage Source converter) technology makes it more realistic to consider real HVDC grids.

The advantage with an HVDC grid is at least the same as with an ac grid. It gives more flexibility and reliability regarding N-1 or N-2 conditions. With converters connected in the nodes the voltage can be controlled and by that the power flow between the nodes.

The challenges with a dc network are several. One is the control of power, another is the protections that will have to be very fast and a third is dc breakers that also have to be much faster than present ac- breakers. In addition dc is more difficult to break than ac. Another consideration is how to do the grounding of a dc grid.

The paper will discuss the advantages and challenges with HVDC grids and also the need for selection of dc voltage levels that will make a dc grid useful over as wide geographic area as possible.

### **KEYWORDS**

HVDC grid overlay net, dc breaker, load flow, protection

### **History**

HVDC was developed more than 50 years ago using LCC (Line Commutated converters). In the first years only point to point transmission were considered. A few years later the idea of building more complex dc grids came up. CIGRE started a working group for DC- breakers and that group was working during more than twenty years studying various aspects of dc grids with more than one line. DC breakers were also developed for lower voltages for use as for instance MRTB (metallic return transfer breakers) and these breakers have been used in

many projects. The first multi terminal projects were the three terminal SACOI (Sardinia-Cosrica- Italy) project and the Quebec- New England scheme. The latter was a big challenge as five terminals were considered originally. By thorough analysis it was possible to make a design without using dc breakers. Later the two smallest terminals were removed from the scheme due to reliability reasons. Disturbances in the ac local network might have caused disturbances in the main dc transmission. After this very few HVDC projects using more than two terminals have been considered and no more multi- terminal HVDC has been built so far.

### **Market need**

During the last fifty years most grid expansion has been done by ac. HVDC has only around two percent of the total transmission market. However, in the countries where the electric grids are undergoing fast expansion HVDC plays a much bigger role. This is because HVDC today is a mature technology.

In the countries with older new challenges are coming up such as integration of renewable energy sources (wind and solar etc) and new load flow patterns by increasing trade. This poses new requirements on the grid. However, the possibilities to build new ac- overhead lines can be difficult due to permitting. Power lines are not seen in the same positive way as they were fifty years ago.

The problem could be solved technically by using underground cables. However, ac cables at 400 or 500 kV can only be used for very short distances (up to around fifty km).

For longer distances dc cables is the only solution for going underground. With more and more HVDC it will soon be interesting to consider joining these links into an HVDC grid. This is already discussed by politicians as “Super grid”

### **Requirements on an HVDC grid**

The requirements on a grid are different from the requirements on a two terminal transmission. The reliability has to be very high. Actually the probability for a total blackout should be in the order of once in hundred years. Parts of the grid could always fail but this should not cause total blackout under any circumstances. Only a long chain of malfunctions should be allowed to cause a blackout.

### **Technical possibilities**

Since the time of Hydro Quebec- New England HVDC transmission (early 1990) HVDC using VSC (Voltage Source Converters) has been developed.

In LCC the dc current can only flow in one direction. This means that changing the power direction means changing the polarity of the transmission. This is not a problem with two terminals, but becomes more problematic with multi- terminal schemes. VSC can allow current in both directions and there is no need to change the polarity when the direction of power is changed. This makes building a dc grid with VSC easier than with LCC.

Another advantage with VSC is that disturbances in the ac grid do not cause commutation failure that severely affects the dc transmission. VSC dc grid will be more immune to disturbances in the ac grid.

### **Load flow control**

In a two terminal transmission the load flow is fully controlled. In a dc grid it might not be possible to control currents in all lines in the same way. This is due to the fact that it is only possible to control the current if the grid has as many branches as nodes. A grid is likely to have much more branches than nodes. One of the advantages with a grid is that fewer converter stations are needed. The drawback is the loss of controllability of the current in the

branches of the grid. Load flow calculations need to be done to make sure that no branch is overloaded.

Below is a grid with four nodes and four branches.

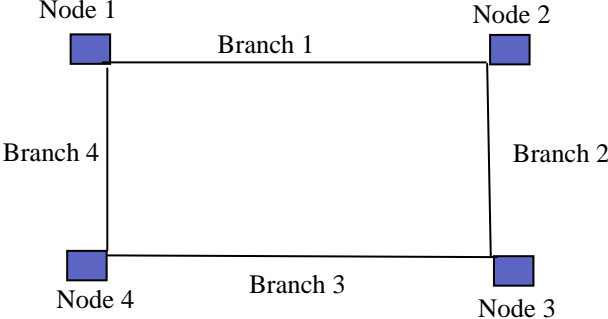

We get the following equations:

$$I_1 = \frac{U_2 - U_1}{R_{12}} \qquad I_3 = \frac{U_4 - U_3}{R_{34}}$$

$$I_2 = \frac{U_3 - U_2}{R_{23}} \qquad I_4 = \frac{U_1 - U_4}{R_{14}}$$

We have four equations and four unknown. Here we get an exact solution which means that all branch currents can be controlled by the node voltages.

If we add two more branches we get the following grid:

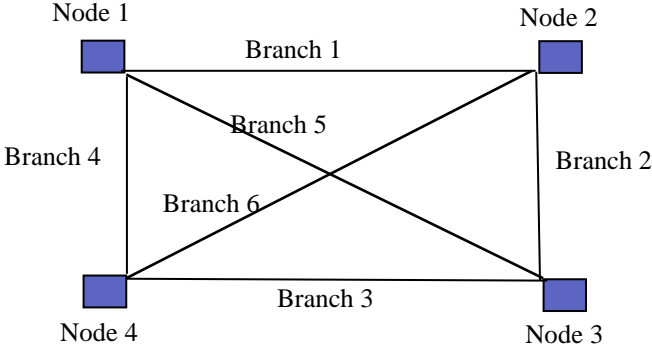

The currents in this grid can be expressed as:

$$I_1 = \frac{U_2 - U_1}{R_{12}} \quad I_4 = \frac{U_1 - U_4}{R_{14}}$$

$$I_2 = \frac{U_3 - U_2}{R_{23}} \quad I_5 = \frac{U_3 - U_1}{R_{13}}$$

$$I_3 = \frac{U_4 - U_3}{R_{34}} \quad I_6 = \frac{U_4 - U_2}{R_{24}}$$

Here we have six currents and four voltages. It will only be possible to get exact control of four currents. The first priority will then be to avoid overloading of any branch. This should normally be possible, but it might lead to low utilization of some branches.

This situation is new for HVDC but typical for ac grids.

### **DC breakers**

There are many challenges to build a dc grid with VSC. Faults on the dc bus or in the dc cables (or lines) are probably the most severe challenge. As a VSC has diodes in the backward direction the ac side will feed current into the dc side fault only limited by the reactance in the ac grid, the converter transformer and the converter phase reactor. In the case of cable transmissions faults on the dc side are very rare. Today in present two terminal schemes these faults are taken care of by opening the breakers on the ac side in both converters. This solution is less attractive when more than two terminals are involved because the whole dc side will lose its voltage for several hundred milliseconds. A solution that maintains the dc voltage on most of the dc grid is necessary for larger grids. The only way to achieve this is to use dc breakers.

The kind of dc breakers that would serve in a dc cable grid does not exist today. The requirements differ from ordinary ac breakers on at least two important parameters. First they will have to break dc, and then they will have to be much faster than ac-breakers. The high speed will be necessary because the impedance in a dc grid is quite low. The fault currents will rise very fast towards very high values unless interrupted within a few milliseconds.

### **HVDC Switchyard**

An HVDC switchyard would look very much the same as an ac switchyard. Below is shown an example of a one and a half breaker switchyard. This configuration would make it possible to maintain the function of the switchyard with a fault on any part of the yard and maintain operation of all healthy cables and converters at a fault at any converter or cable.

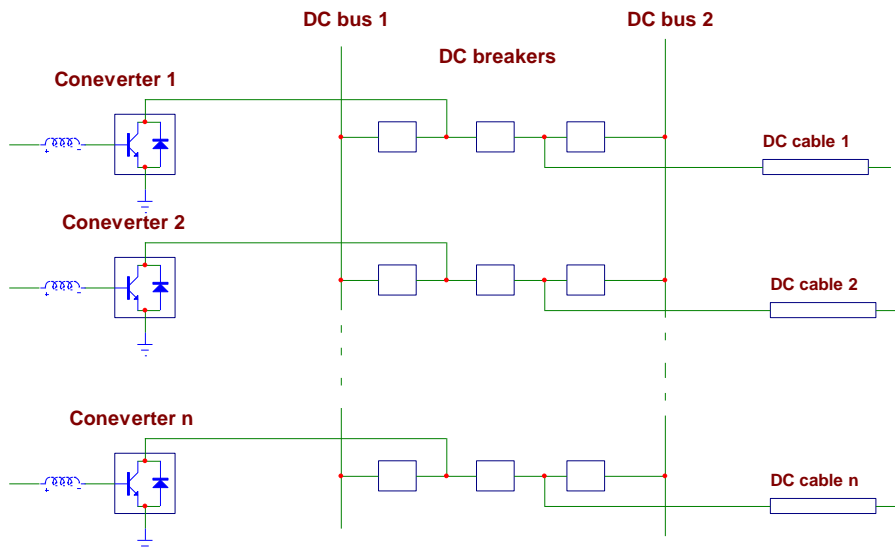

### Protection

DC breakers protections have to be designed to make sure that only the faulted part of the grid is disconnected. The protections also have to make sure that if zone one protections does not operate properly a zone two protections should operate and take out a somewhat bigger part of the grid. The major part of the grid should still be able to continue operation. Also third zone protections would be needed if the grid is very big.

### Standards

As long as HVDC was mainly point to point transmission the need of standardisation was not urgent. With HVDC grids the situations changes as in this case the grid will inevitably have to be built in stages and the different parts will have no contact with each other in the beginning. If voltage, protection principles and load flow control is not in some way standardized it might not be possible to connect the different parts into an overall grid. This makes it important to have an early discussion on standards at a time already when the real grid seems far away. This time is probably now.

### Future

Should the technical development of a dc grid be successful the rewards are very big. Then power could flow over very large distances from new generation sources. Trade of electricity could be made in a very efficient way reducing cost for the consumers in a whole continent.



The picture shows a possible future dc grid covering most of Europe making it possible to utilise massive influx of wind power from the sea, solar energy from the south, hydro power from the mountainous areas and overall trade between countries.

### **Conclusion**

A dc grid could serve a lot of future needs in the transmission area. Voltage Source Converters make it easier to construct dc grids but there are many issues still to solve before these grids can become reality.

### **BIBLIOGRAPHY**

- [1] Asplund, G, Eriksson, K, Svensson, K: “DC Transmission based on Voltage Source Converters”, Cigré SC14 Colloquium on HVDC and FACTS in South Africa, 1997.
- [2] Asplund, G, Eriksson, K, Drugge, B: “Electric power transmission to distant loads by HVDC Light”, Distribution 2000, Sydney, Australia, 1997.
- [3] Asplund, G, Eriksson, K, Jiang, H, Lindberg, J, Pålsson, R, Svensson, K: “DC Transmission Based on Voltage Source Converters”, Cigré Conference, Paris, France, 1998.
- [4] Ana Diez Castro & Rickard Ellström, Ying Jiang Häfner, Christer Lijlegren “Co-ordination of parallel AC-DC System for Optimum Performance” DistribuTech, Madrid. September 1999
- [5] L. Stenius, K. Eriksson, “HVDC Light – An excellent tool for City Center Infeed”, PowerGen Conference, Singapore, September 1999.

- [6] Weimers L. "New Markets Need New Technology", Powercon 2000, Perth Australia , Dec 2000.
- [7] Christer Liljegren "Wind Power in the local Grid Problems and solutions"  
Conference Wind Power on island, Gotland Sweden September 2001
- [8] P. Fischer de Toledo, "Feasibility of HVDC for City Infeed", Licentiate Thesis, Royal Institute of Technology, Stockholm 2003.
- [9] B. Normark, D. Ravemark, "Underground transmission with HVDC Light", ABB Review, 2005.
- [10] S. G. Johansson, G. Asplund, E. Jansson, R. Rudervall, "Power System Stability Benefits with VSC DC-Transmission Systems", Cigré B4-204, Session 2004.
- [11] Stefan G. Johansson, G. Asplund, E. Jansson, R. Rudervall: "Power System stability benefits with VSC DC-Transmission Systems", Cigré conference, Paris, France, Aug. 29 - Sept. 03, 2004
- [12] L. Ronström , B. D. Railing, J. J. Miller, P. Steckley, G. Moreau, P. Bard, J. Lindberg, "Cross Sound Cable Project Second Generation VSC Technology for HVDC", Cigré Session B4- 104 2004.
- [13] Costas Papadopoulos\*, Paris Papageorgiou, Lars Stendus, Johan Åhström, Mats Hyttinen, Dr Stefan Johansson, Interconnection of Greek islands with dispersed generation via HVDC Light Technology, Athens, Greece April 2005:
- [14] B. Jacobsson, Y. Jiang-Häfner P. Rey G. Asplund ,M. Jeronense, A. Gustafsson, M. "HVDC with voltage source converters and extruded cables for up to  $\pm 300$  kV and 1000 MW" CIGRE Paris, France, August 2006
- [15] Lianxiang Tang; Boon-Teck Ooi, Power Delivery, Locating and Isolating DC Faults in Multi-Terminal DC Systems IEEE Transactions on Volume 22, Issue 3, July 2007