

Valhall re-development project, Power from shore

Sverre Gilje
BP Norge AS
Godesetdalen 8, P.O. Box 197,
4065 Stavanger, Norway

Mats Hyttinen
ABB AB
SE-771 80 Ludvika
Sweden

Bo Westman
ABB AB
SE-771 80 Ludvika
Sweden

SUMMARY

A new platform will be built adjacent to the existing Valhall facilities in the North Sea between Norway and Scotland.

The new platform as well as all the existing equipment on the Valhall field will be supplied with electric power from shore, PFS, through a HVDC Light transmission using the VSC technology. This is the first time HVDC is used to supply an entire offshore AC system.

This paper discuss the design, installation and testing of the VSC converters. The onshore converter is starting operation as an SVC to support the network during the time when the offshore converter module is being built.

KEYWORDS

HVDC, Valhall, transmission, Power from shore.

1. INTRODUCTION

The existing Valhall complex, in operation since 1982, consists of five bridge-linked platforms. In addition, three wellhead platforms, Hod, Valhall Flank South and North, have been installed about six km each, from the Valhall complex. The Valhall facilities are subject to reservoir compaction resulting in seabed subsidence (about 25 cm per year) and as a result the water depth at site has increased by about 5 meters. Based on wave consideration and impact on air gap and operation of the original facilities, it has been recommended to replace the production and compression platform and the living quarter platform with a new facility in 2010.



Figure 1: The existing Valhall complex.

This new facility will be supplied with electric power from shore (PFS) through a High Voltage Direct Current (HVDC) transmission utilizing the latest development in power electronics and computerized control and protection systems. The transmission system based on voltage sourced converters (VSC) will include onshore and offshore converter stations joined by a 292 km cable. The transmission system will convert AC power from the 300 kV sub-station at Lista to DC power at 150 kV, transmit it through the sub-sea DC cable and convert it back to AC at 11 kV at the new platform to feed the entire Valhall field.

The system for Valhall will replace offshore gas turbines and deliver up to 78 Megawatt power to run the complete field. This will make Valhall one of the most environmental friendly fields off Norway's shores. Following the final installation the user will also achieve a safer and more effective source of power supply, resulting in less maintenance and a lighter platform solution.



Figure 2: Map over the transmission system

HVDC transmissions have been built for more than half a century with a capacity of a single converter up to about 3000 MW at a transmission voltage up to ± 800 kV. Applications have normally been bulk transmissions from distant power generation, long underground or sub-sea cable transmissions or asynchronous ties between different power systems.

Applications to feed power to or from offshore installations, using HVDC, have been discussed for many years. However, due to the nature of conventional HVDC which requires certain strength of AC system to operate, this has not been feasible in the past. Not until the VSC technology was developed more than ten years ago. The new technology is based on transistors as opposed to the conventional HVDC, which use thyristors. This difference makes the new converters self commutated i.e. they do not require an existing AC voltage to operate, but can feed into a completely passive load.

The first application of the VSC technology was put into operation in 1997 and two years later the first commercial project was commissioned on the island of Gotland, Sweden. A total of eleven VSC transmission systems are now in operation in different parts of the world.

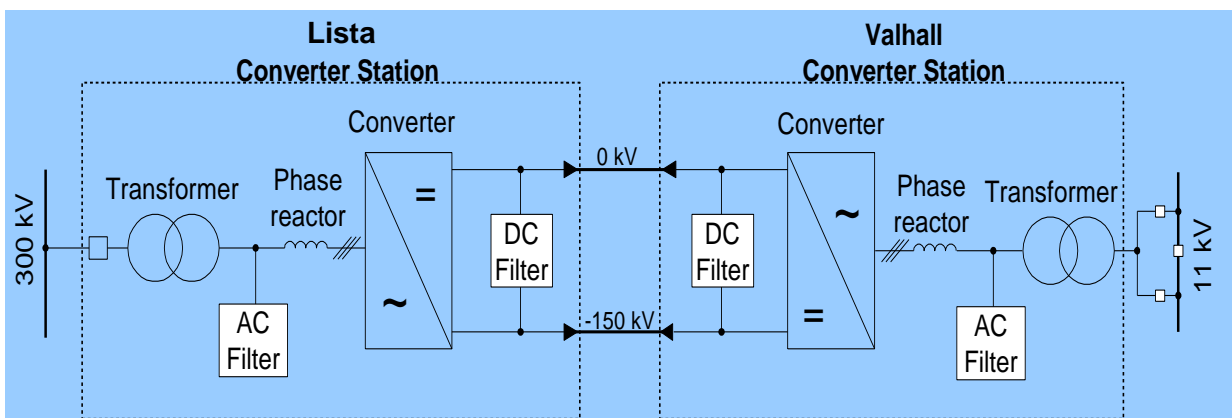

Figure 3: Single Line Diagram of power from shore with HVDC.

The first offshore application was commissioned early 2005 to feed the new compressors on the Troll A platform outside Bergen, Norway. This is a double circuit, 2 x 40 MW sub-sea HVDC cable installation from Kollsnes to the Troll A platform 67 km offshore feeding two large compressors. The Valhall, Power from shore project, is different from Troll in one very important aspect. This is the first time a complete offshore power system for an entire field will be fed with electric power from the mainland using HVDC.

2. HEALTH, SAFETY AND ENVIRONMENT (HSE)

Power from shore is cost efficient and have the advantages that it will save space and weight on the platform itself. This solution also requires less maintenance offshore than the conventional solution with gas turbines. Last, but not least, it will contribute to a safer working environment on the platform as well as being more environmentally sound since emissions are reduced.

The main factors for selection of Power from shore with HVDC for the Valhall Re-Development project were:

- Reduce costs and improve operation efficiency of the field
- Minimize emission of climate gases
- Improve all HSE elements

3. VSC TRANSMISSION

With VSC transmission technology, the use of series-connected power transistors has allowed to connect voltage-source converters to networks – at voltage levels hitherto beyond reach. This can be used for power transmission, for reactive power compensation and for harmonic/flicker compensation.

In the VSC converter, Pulse Width Modulation, PWM is used for generation of the fundamental voltage. Using PWM, the magnitude and phase of the voltage can be controlled freely and almost instantaneously within certain limits. This allows independent and very fast control of active and reactive power flows. PWM VSC (Voltage Source Converter) is therefore a close to ideal component in the transmission network. From a system point of view, it acts as a zero-inertia motor or generator that can control active and reactive power almost instantaneously. Furthermore, it gives only a limited contribution to the short-circuit power, as the AC current can be controlled.

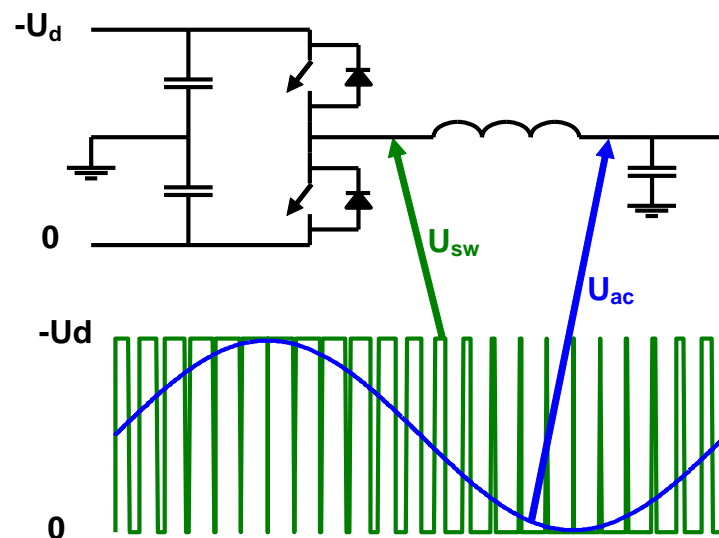

Figure 4. Principle of pulse width modulation, PWM.

The HVDC converter design for Valhall is based on the two-level bridge but with the midpoint of the capacitor floating. The switching of the bridge between 0 kV and -150 kV makes optimal use of the coaxial HVDC cable design with the center conductor at high voltage and the return conductor close to the grounded screen. The design philosophy enables operation both steady state and dynamic, with extremely low levels of induced ground currents. This feature is one of the critical factors for implementing an HVDC system in an offshore environment. There is no need for any cathode protection in conjunction with the installation.

The design principles adopted for normal transmission system applications can also be used to feed a local offshore AC network such as the Valhall complex.

Some of the more important benefits with an HVDC transmission feeding a platform are:

- Control of AC voltage and frequency
- Direct On Line start of large asynchronous machines
- Ride through of mainland AC system disturbances

The performance of the HVDC transmission system together with the platform AC system has been verified in simulations using EMTDC, an Electro Magnetic Transient Stability Program for simulation of e.g. power transmission systems. The simulation set-up includes an equivalent of the mainland AC network, a detailed model of the HVDC main circuits including e.g. a switching converter bridge, filters, a DC cable model and extensive representation of the Valhall platform AC network.

The 11 kV distributions on the new production and hotel platform is divided into two busses, with major compressors and pumps split between them and connected directly on the 11 kV level.

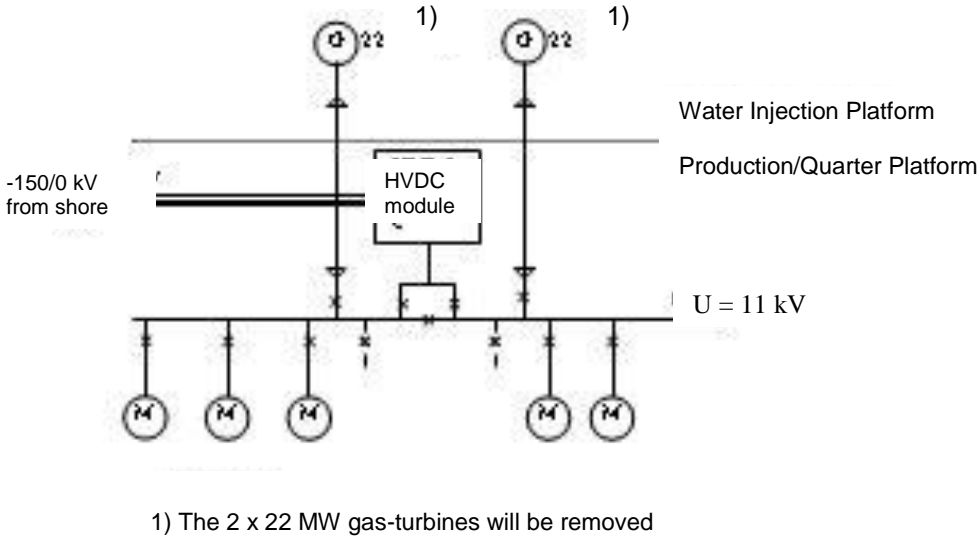

Figure 5. Single line diagram of the AC system on Valhall fed by power from shore.

The performance has been verified by investigating a variety of faults and disturbances in the AC systems as well as Direct On Line starts of large induction motors (up to 15 MW).

Figure 6 below illustrates a simulation of Direct On Line start of a 15 MW motor.

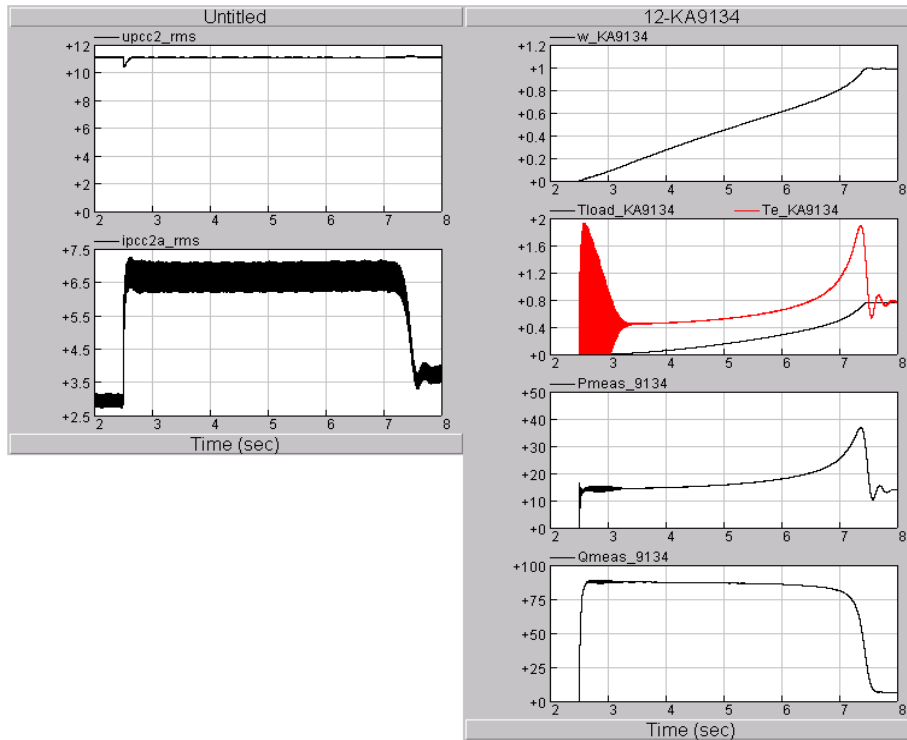

Figure 6. Illustration of simulation DOL motor start

Figure 6 above, shows from upper left to lower right; AC bus voltage in kV, total current in-feed to the platform in kA, motor speed in p.u., motor and load torque, active and reactive power drawn by the starting motor. The figure illustrates that the VSC converter compensates almost momentarily for the active and reactive power needed by the accelerating motor. The bus voltage is therefore almost unaffected. It is only in the very first moments that a small dip can be seen.

4. OFFSHORE CONVERTER

Space and weight are scarce resources on offshore installations. Particularly in the light of these constraints, the VSC converter concept offers important advantages. Since the filters are small, it can be made compact and lightweight compared to other solutions.

The high voltage equipment has been installed inside a module offshore and indoor a building onshore. The ventilation system in the module/building will be designed to protect the high-voltage equipment and the electronics from salt and humid air. The main circuit equipment is therefore exposed to lower environmental requirements than a normal outdoor installation, which allows for a more compact design.

The HVDC module will be built in two stores with the AC filters and phase reactors on the top floor and the converter valves and the DC equipment below. This is also where the 150 kV HVDC cable is terminated. The converter transformers will be located in a separate room with the bushings penetrating through the walls to the phase reactors and to the 11 kV AC side respectively. AC filters are located on both sides of the transformer to reduce harmonics to the platform AC system to a minimum.

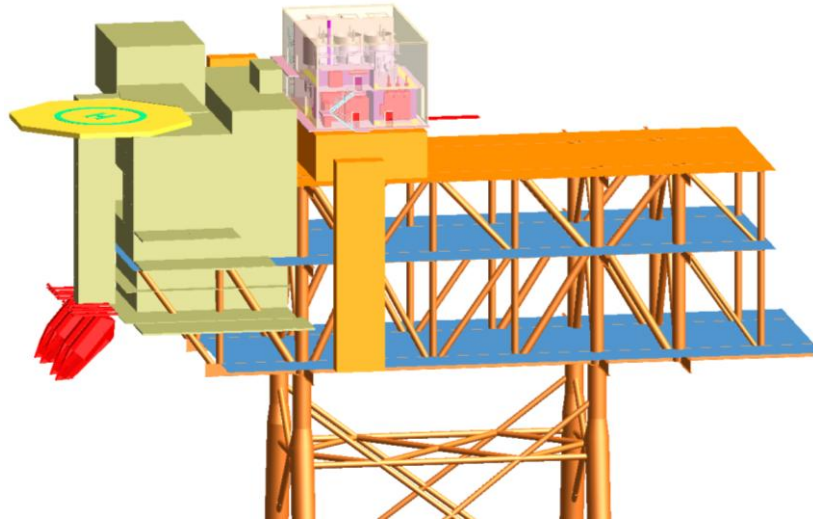

Figure 7. The new Valhall production and hotel platform with the HVDC module on top.

The size of the HVDC module as shown in Figure 8 below is: 17 x 30 x 13.6 m (W x L x H)

In this volume there is not only room for the high voltage equipment but also the auxiliary systems, mainly the valve cooling system, the ventilation system and the auxiliary power system. There are also two electrical rooms for the HVDC control and protection equipment and for communication with the platform control system.

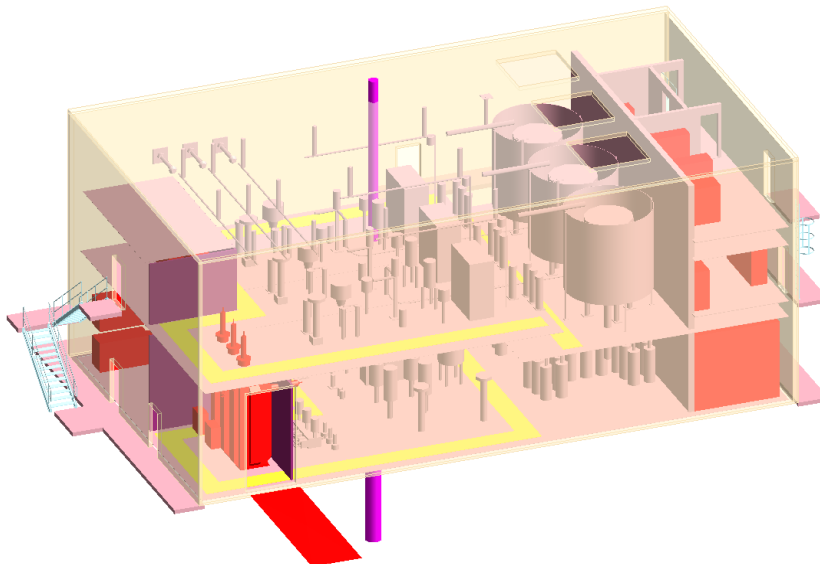

Figure 8. A closer look into the HVDC module

5. ONSHORE CONVERTER, NETWORK SUPPORT

The onshore converter station is located at Lista and connected to the Norwegian 300 kV power grid through a double circuit line to Fedaa. The principal layout for the converter at Lista is essentially the same as on the Valhall platform with two major exceptions. The AC voltage at Valhall is 11 kV while it is 300 kV at Lista. The AC switchyard is therefore built as a conventional outdoor installation with one AC breaker but with two disconnectors which makes it possible to connect Valhall to either of the two busses in the existing switchyard. The other major difference is the cooling system for the valves. At the platform, seawater is the final media for cooling. At Lista dry cooling towers are used to cool against the outdoor air.

The inverter control software is adapted to perform voltage and frequency control – while the control hardware is identical for rectifier and inverter converters. Protection and monitoring of the converter is also included in the same controller.



Figure 9. HVDC converter station at Lista

The VSC converter has an advantage in that it can operate standalone i.e. the onshore converter can operate without connecting the DC cable to offshore. This operation mode will never be used when the complete system is in operation, but it has an advantage during the commissioning phase as the onshore station can be fully commissioned and put in operation prior to start the offshore installation, which reduces commissioning time. In addition, operational training can be performed, which is especially important with a new system to be integrated into the operation organization. Furthermore the ability of the converter to operate as a static var compensator, SVC, also makes it a tool for network support. The plan is to have it in operation as network support with the VSC converter in AC voltage control mode in the intermediate period before the offshore system is installed. Some network support will also be possible during normal operation, but this will be limited by the power transmission to offshore. The available reactive power capability is shown in Figure 10 below.

The Lista station was not originally designed to be an SVC, but only to supply the offshore installation with active power. However, later analysis revealed a capability of roughly ± 85 MVar depending on AC voltage. The dependency of AC voltage is due to the fact that the converter was designed without tap-changers on the transformers. This is however not a practical limitation, since the capability to absorb reactive power is max at maximum voltage and vice versa; the capability to generate is max at minimum voltage.

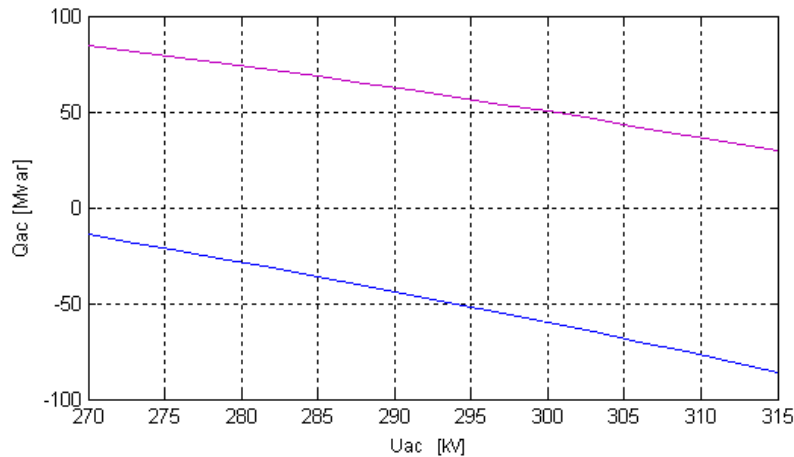

Figure 10: Reactive power capability of the Lista station.

6. EXPERIENCE FROM INSTALLATION AND COMMISSIONING

The work at Lista with civil work, installation and commissioning has had a strong focus on HSE. The consequences have been:

- No harm to people or to the environment with zero accidents and loss of work.
- Good working environment
- Well planned and efficient work

An important factor for these types of installations is comprehensive factory testing of all parts of the equipment, especially the control and protection system. From first time energization to heat run was one week of testing including a normal set of commissioning issues. One of the issues in Valhall is the unbalanced bridge with zero and -150 kV which where the AC voltage measurement had to be done with a DC voltage divider. This caused some difficulties with low order harmonics until the difference in measuring characteristics could be compensated for in the control system. For these types of events it is important to have a good simulation tool where corrections can be made and verified fast.

The Lista station is completed and will start being in commercial operation as an SVC in March 2009.

The work with the Valhall project now focuses on the offshore station where installation onshore is about to start. One important aspect is that most of the installation and commissioning for the offshore module is done onshore in order to minimize offshore activities.

7. CONCLUSIONS

The technology using VSC technology makes it possible to supply electric power from shore to offshore installations.

The benefits with power from shore for Valhall can be summarized as follows:

- Simplified offshore installation, lower offshore manning and reduced operation costs
- Improved safety and working environment
- Emission to air offshore close to zero for energy supply to the complete Valhall field
- Fewer offshore lifts give HSE benefits
- Less boats, less helicopters

- Technical advantages regarding Direct On Line start of large motors and electrical system fault level in the offshore grid

Power from shore is cost efficient, saves space and weight on the platform itself, requires less maintenance offshore than the conventional solution with gas turbines. It will also contribute to a safer working environment on the platform as well as being more environmentally sound by reducing emissions.

The onshore station can and will be fully commissioned and put in operation as network support while waiting for the offshore installation.

BIBLIOGRAPHY

- [1] Asplund, Eriksson, Jiang, Lindberg, Pålsson, Svensson: DC transmission based on voltage source converters, Cigré SC14 Session, Paris, 1998.
- [2] Axelsson U, Holm A, Liljegren C, Åberg M, Eriksson K, Tollerz O.: The Gotland HVDC Light project – experiences from trial and commercial operation; CIRED 2001, Amsterdam, Netherlands, June 2001.
- [3] Hörle N, Eriksson K, Maeland A, Nestli T.: Electrical supply for offshore installations made possible by use of VSC technology.
- [4] Hyttinen M, Lamell J-O, Nestli T.: New application of voltage source converter (VSC) HVDC to be installed on the gas platform Troll A.